

**Technical data**

HRN-100	
Supply	2
Supply and measuring terminals	L1, L2, L3, (N)
Supply and monitored voltage	$U_{ln} = 3 \sim 90 - 288 \text{ V, (AC 45-65 Hz)}$ $U_{ll} = 3 \sim 155 - 500 \text{ V, (AC 45-65 Hz)}$
Power consumption (max.)	5 VA
Measuring circuit	
Selection of the measured circuit	Phase voltage - 3 phase, 4 wire Line voltage - 3 phase, 3 wire
Adjustable upper (OV) and lower (UV) voltage levels	Phase voltage: 90 - 288 VAC Line voltage: 155 - 500 VAC
Upper (HC) / lower (LC) limit voltage	Phase voltage: 310 VAC / 85 VAC Line voltage: 535 VAC / 150 VA
Adjustable upper (OF) and lower (UF) frequency level	45 - 65 Hz
Adjustable asymmetry	5 - 99 VAC / 2 - 50%
Adjustable voltage and frequency hysteresis level	3 - 20 VAC (OV,UV, HC, LC) 0.5 - 2 Hz (OF, UF)
Adjustable hysteresis asymmetry	3 - 99 VAC / 2 - 15%
Accuracy of measured voltage	+/- 5V
Accuracy of measured frequency	+/- 0,3 Hz
Adjustable delay after supply connection $P_{on}$	1.5 sec 0 - 999 s (HW initialization 250 ms)
Adjustable delay $T_{on}$	0,5 - 999 s
Adjustable delay $T_{off}$	0,1 - 999 s
Fixed delay	<100 ms (phase sequence, failure) <200 ms (HC, LC), <500 ms (neutral fail)
Output	
Number of contacts	2x CO (AgSnO <sub>2</sub> )
Rated current	5A/AC1
Switching power	1200VA/AC1, 150W/DC1
Switched voltage	240V AC/30V DC
Max. output power dissipation	5W
Mechanical life (AC1)	1x10 <sup>7</sup>
Electrical life	1x10 <sup>3</sup>
Other data	
Operating temperature	-10.. +60 °C
Storage temperature	-20.. +70 °C
Electrical strength	4kV (supply - output)
Operating position	any
Mounting	DIN rail EN 60715
Protection degree	IP20 terminals/IP40 from front panel
Overvoltage category	III
Pollution degree:	2
Cable size	max. 1x 2,5 mm <sup>2</sup> , max. 2x 1,5 mm <sup>2</sup> / with sleeve max. 1x 2,5 mm <sup>2</sup>
Dimensions:	90 x 36 x 66,5 mm
Standards:	EN 60255-1:2010, EN 60255-26 + AC:2013, EN 60255-27:2014, EN 50581:2012 + Z1:2019

**Description**

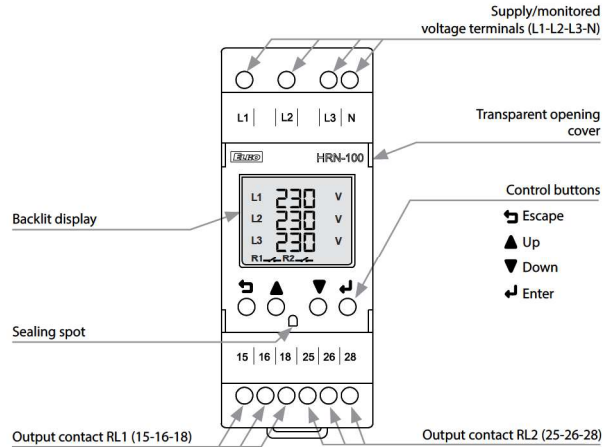

**Controlling elements**

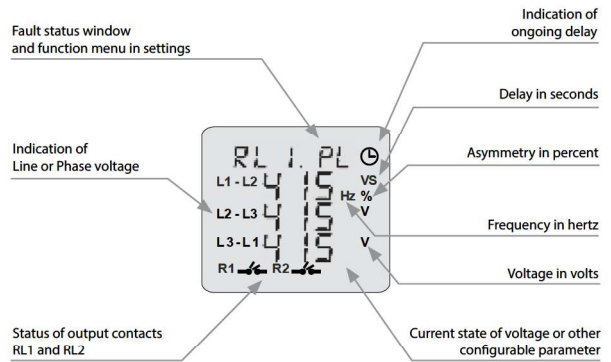

**Frequency and voltage monitoring relay HRN-100**

Type	$I_n$ [A]	Code No.		
HRN-100	2 x 5 A (AC1)	002470303	132	1

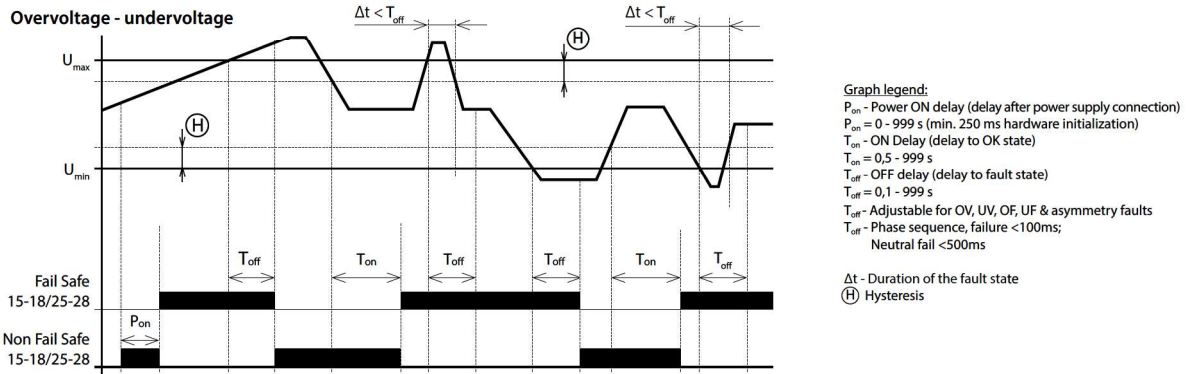

- After the supply/monitored voltage is connected, the delay  $P_{on}$  starts timing - during the timing the output contact is in a fault state - in the FAIL SAFE mode it is open. After the delay, if the monitored voltage is in the range  $U_{min} \dots U_{max}$ , the output contact closes.
- If the monitored voltage exceeds the set value  $U_{max}$ , the time delay to the fault state ( $T_{off}$ ) starts. After the delay, the output contact opens.
- If the monitored voltage falls below the  $U_{max}$  value reduced by the set hysteresis, the time delay start to OK state ( $T_{on}$ ). After the delay, the output contact closes.
- If the duration of the fault state ( $\Delta t$ ) is shorter than the set value  $T_{off}$ , the status of the output contact does not change.
- If the monitored voltage falls below the value  $U_{min}$ , the time delay to the fault state ( $T_{off}$ ) starts. After the delay, the output contact opens.
- If the monitored voltage exceeds the value  $U_{min}$  increased by the set hysteresis, the time delay start to the OK state ( $T_{on}$ ). After the delay, the output contact closes.
- If the duration of the fault state ( $\Delta t$ ) is shorter than the set value ( $T_{off}$ ), the status of the output contact does not change.

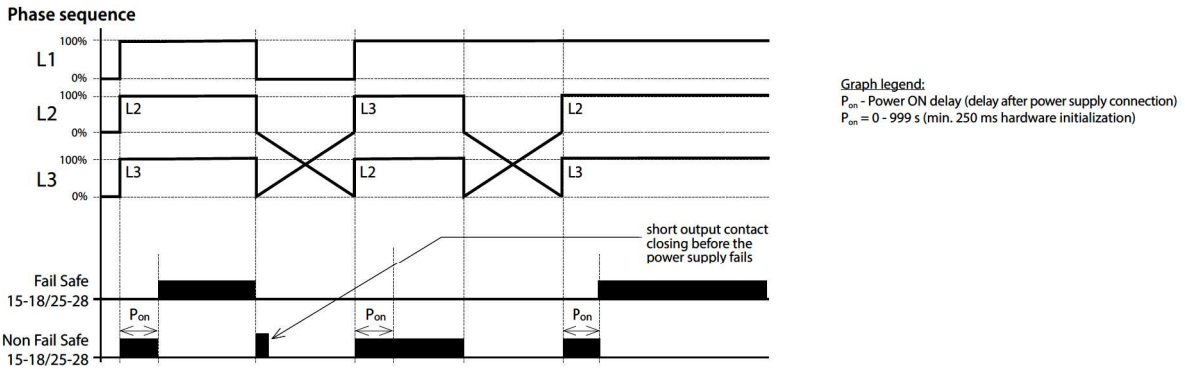

- After the supply/monitored voltage is connected, the delay  $P_{on}$  starts timing - during the timing the output contact is in a fault state - in FAIL SAFE mode it is open. After the delay, if the phase sequence is correct, the output contact closes.
- If the phase sequence is incorrect after the  $P_{on}$  delay, the output contact remains open (fault state).

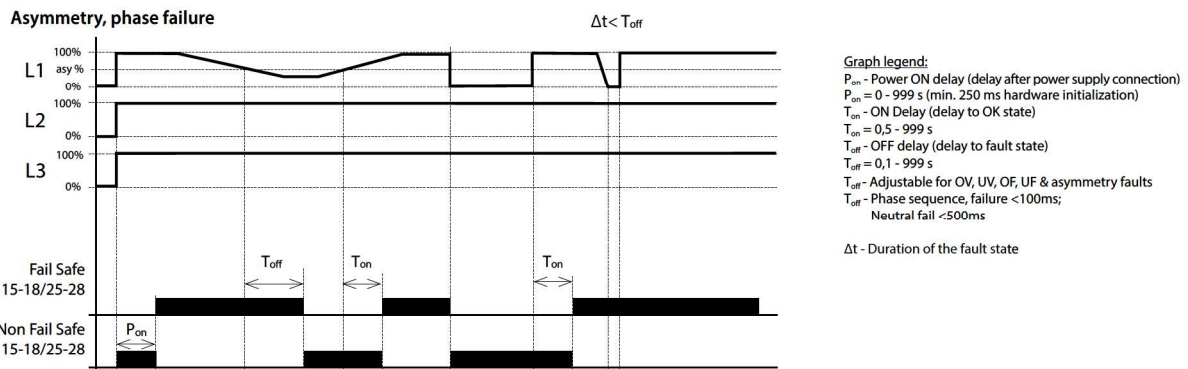

- After the supply/monitored voltage is connected, the delay  $P_{on}$  starts timing - during the timing the output contact is in a fault state - in the FAIL SAFE mode it is open. After the delay, if the phase asymmetry is lower than the set value (absolute or percentage), the output contact closes.
- If the phase asymmetry exceeds the set value, the time delay to the fault state ( $T_{off}$ ) begins. After the delay, the output contact opens.
- If the phase asymmetry falls below the set value, the time delay starts to OK state ( $T_{on}$ ). After the delay, the output contact closes.
- If the duration of the fault state ( $\Delta t$ ) is shorter than the set value  $T_{off}$ , the status of the output contact does not change.
- If a phase failure occurs, the time delay to the fault state ( $T_{off}$ ) begins. After the delay, the output contact opens.
- If the phase failure resumes, the time delay starts to OK state ( $T_{on}$ ). After the delay, the output contact closes.
- If the duration of the fault state ( $\Delta t$ ) is shorter than the set value  $T_{off}$ , the status of the output contact does not change.